

# SIDARA®

## Sospensioni Idrauliche Modulari

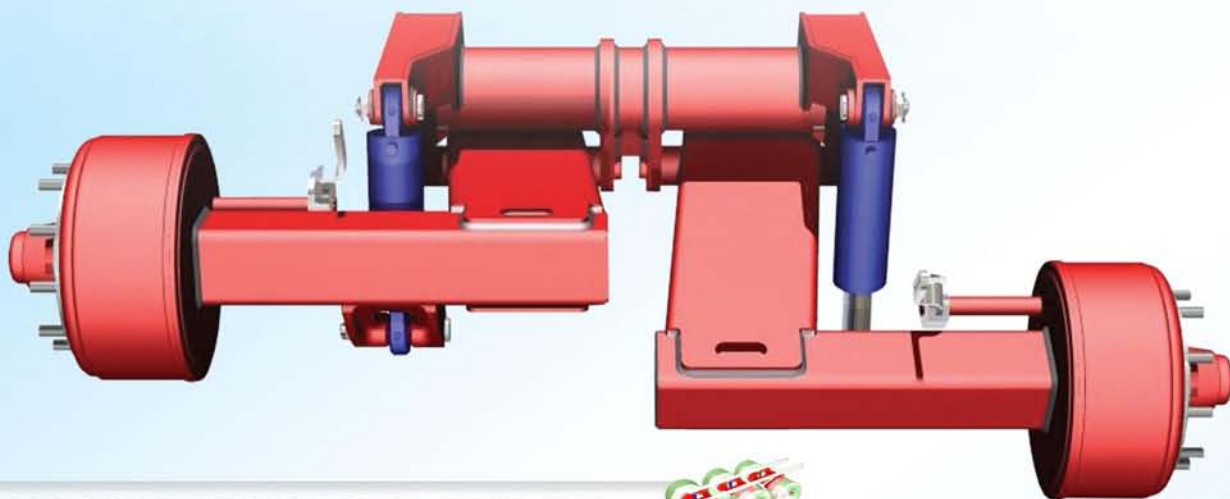

**MONOASSE - TANDEM - TRIDEM**



**CILINDRI TUFFANTI E DOPPIO EFFETTO**



**FISSO, AUTOSTERZANTE, STERZATURA PILOTATA**



**PORTATA 9 TON. - 12 TON. - 14 TON. PER MODULO**



### RUOTE INDIPENDENTI

**PERFORMANCE**

**CONFORT DI MARCIA SIA VUOTO CHE A PIENO CARICO  
CARICO COSTANTE SULLE RUOTE IN OGNI SITUAZIONE  
BLOCCAGGIO ASSE POSTERIORE PER RIBALTABILI  
FACILITA' DI SUPERAMENTO FORTI DISLIVELLI  
ANTIROLLIO E ANTIBECCHEGGIO  
SOLLEVAMENTO PRIMO ASSE  
FRENATURA UNIFORME**

*Il Valore  
dell'Innovazione*



D.B.D. spa  
Tel. +39 0376 520107 - Fax +39 0376 520172  
E-mail [info@dbdcomponents.it](mailto:info@dbdcomponents.it) [www.dbdcomponents.it](http://www.dbdcomponents.it)

seller for foreign countries  
**FAD ASSALI**

# SIDARA®

*Hydraulic Modular Suspensions*

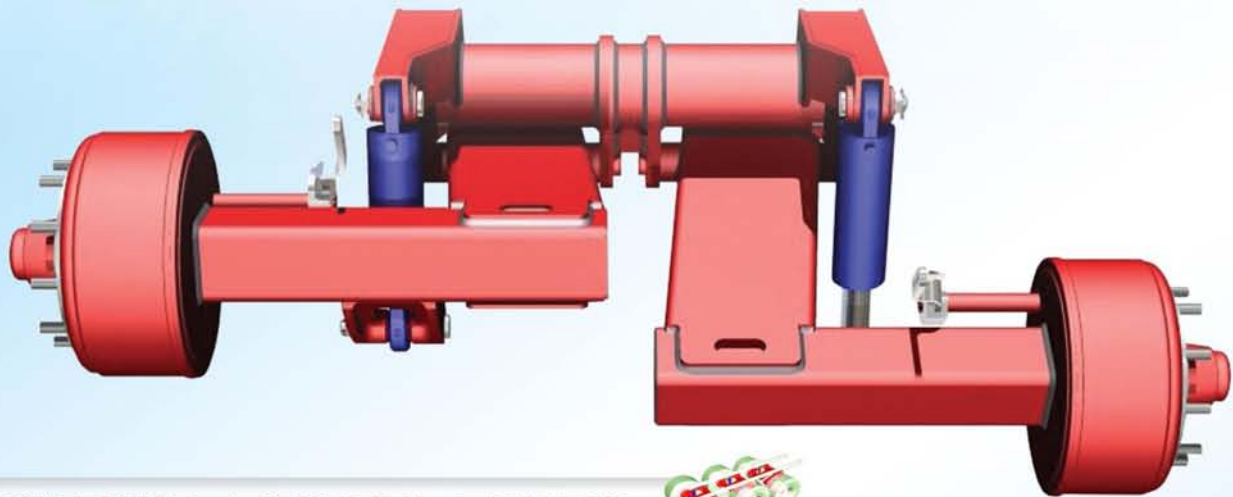

**SINGLE AXLE - TANDEM - TRIDEM**



**FIX, SELF-STEERING, FORCED STEERING**



**SINGLE AND DOUBLE EFFECT CYLINDERS**



**CAPACITY 9 TON. - 12 TON. - 14TON. EACH MODULE**



## INDEPENDENT WHEELS

**PERFORMANCE**

**CONSTANT LOAD ON WHEELS IN ALL SITUATIONS  
RIDE QUALITY BOTH EMPTY AND FULL LOAD  
BLOCKING FOR REAR AXLE DUMPERS  
EASE EXCESS ON STEEP SLOPES  
ANTIROLL AND ANTIPITCHING  
LIFTING OF THE FRONT AXLE  
UNIFORM BRAKING**

*The Value  
of Innovation*



D.B.D. spa  
Tel. +39 0376 520107 - Fax +39 0376 520172  
E-mail [info@dbdcomponents.it](mailto:info@dbdcomponents.it) [www.dbdcomponents.it](http://www.dbdcomponents.it)

seller for foreign countries  
**FAD ASSALI**